

The resultant of the *difference* between two vectors **A** and **B** of the same type may be expressed as

$$\mathbf{R}' = \mathbf{A} - \mathbf{B} = \mathbf{A} + (-\mathbf{B})$$

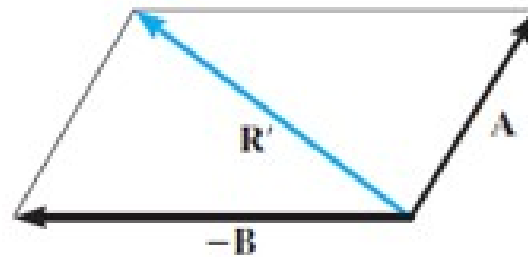

or

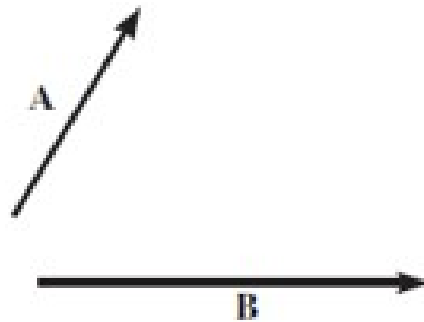
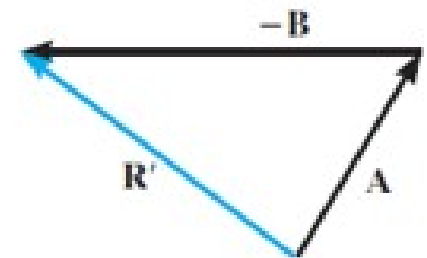

Parallelogram law

Triangle construction

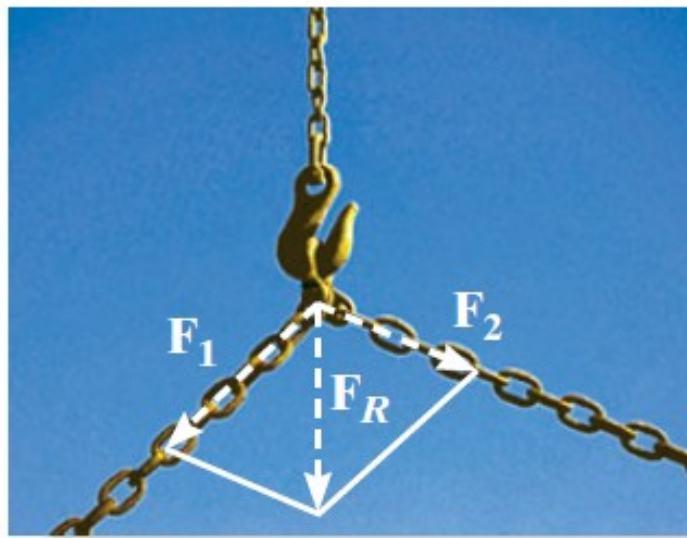

The parallelogram law must be used to determine the resultant of the two forces acting on the hook.

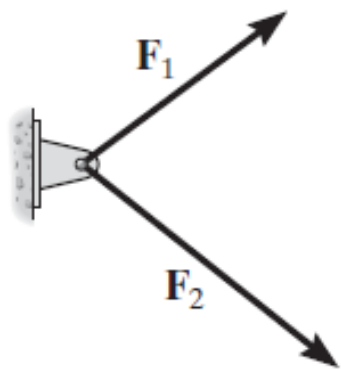

(a)

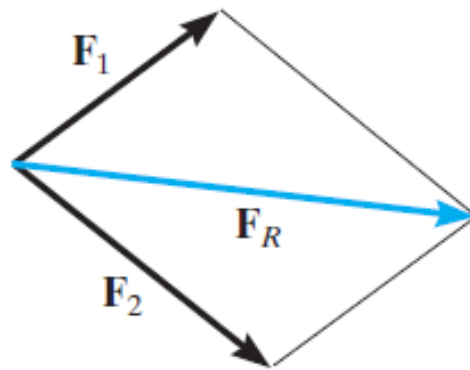

(b)

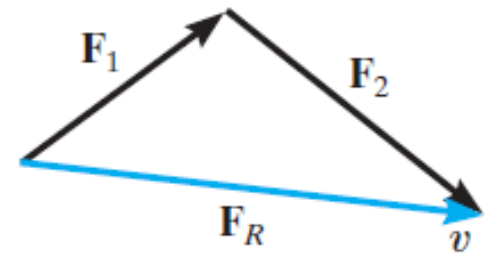

(c)

Important Math

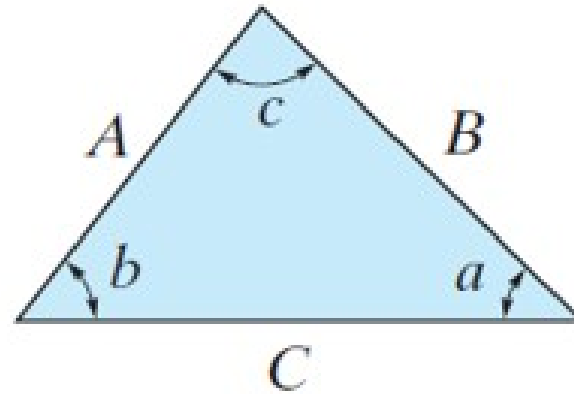

Cosine law:

$$C = \sqrt{A^2 + B^2 - 2AB \cos c}$$

Sine law:

$$\frac{A}{\sin a} = \frac{B}{\sin b} = \frac{C}{\sin c}$$

Contoh 1

The screw eye in Fig. 2–11a is subjected to two forces, \mathbf{F}_1 and \mathbf{F}_2 . Determine the magnitude and direction of the resultant force.

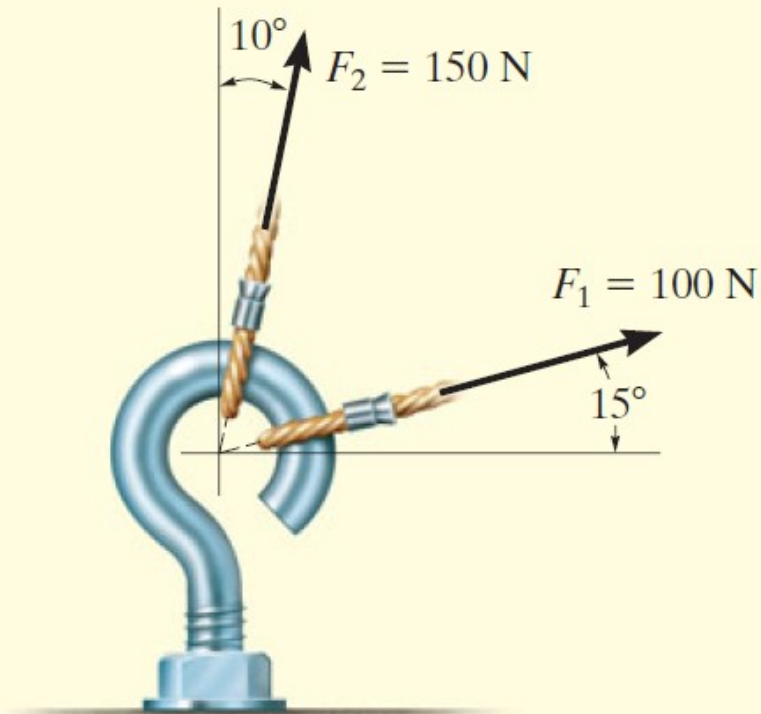

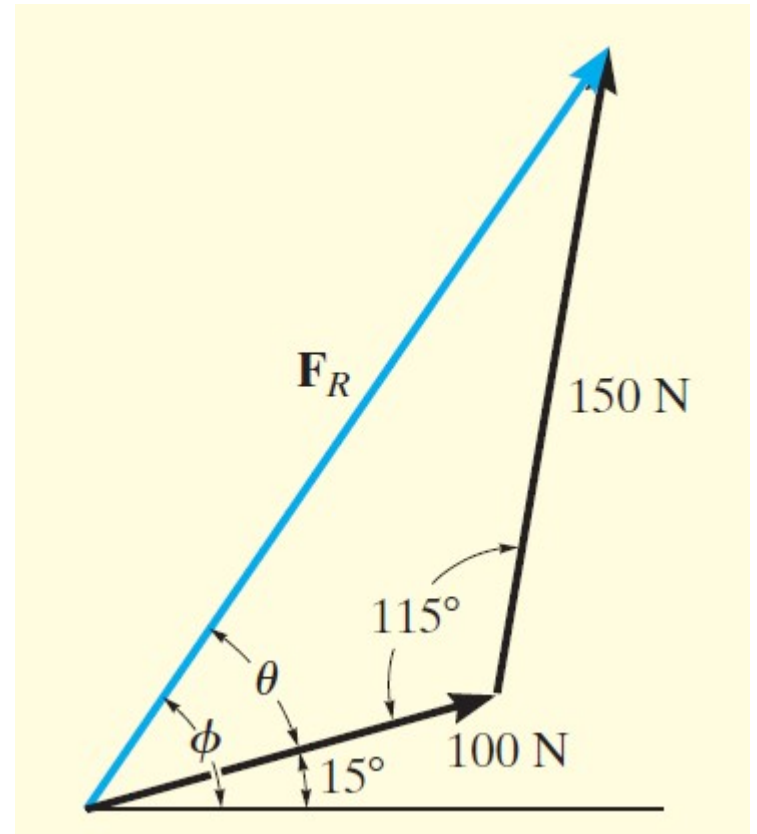
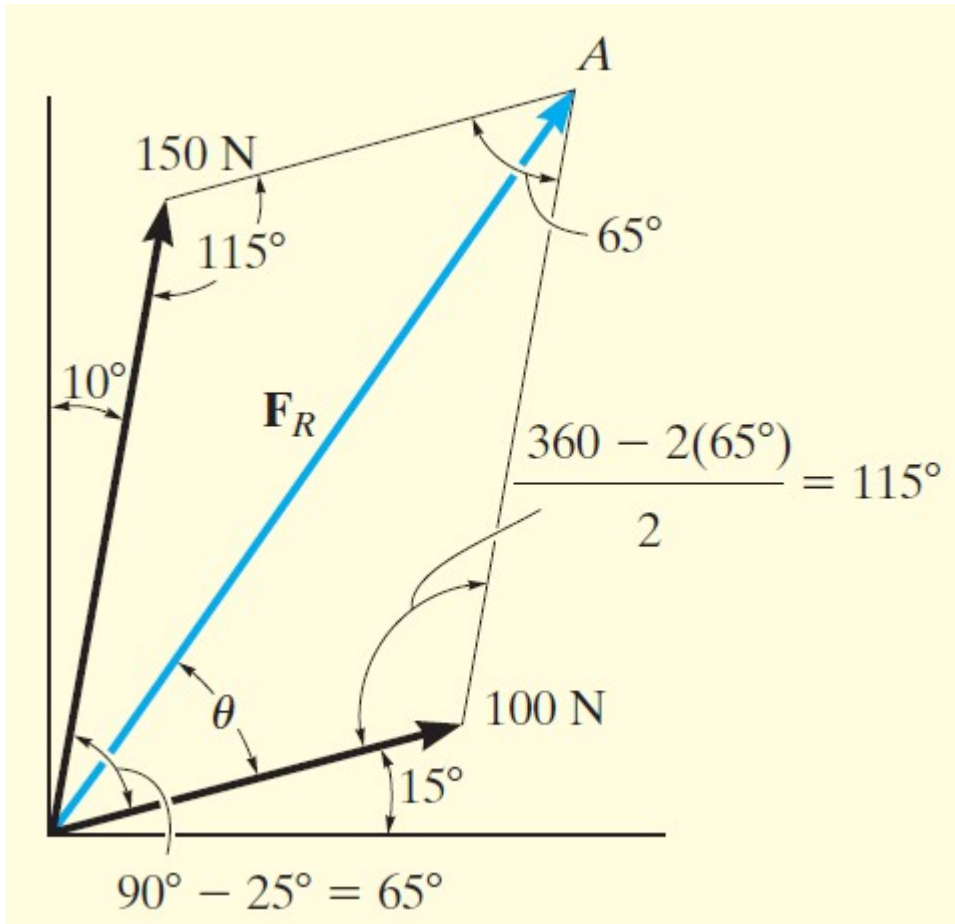

$$\begin{aligned} F_R &= \sqrt{(100 \text{ N})^2 + (150 \text{ N})^2 - 2(100 \text{ N})(150 \text{ N}) \cos 115^\circ} \\ &= \sqrt{10\,000 + 22\,500 - 30\,000(-0.4226)} = 212.6 \text{ N} \\ &= 213 \text{ N} \end{aligned}$$

Applying the law of sines to determine θ ,

$$\begin{aligned} \frac{150 \text{ N}}{\sin \theta} &= \frac{212.6 \text{ N}}{\sin 115^\circ} & \sin \theta &= \frac{150 \text{ N}}{212.6 \text{ N}} (\sin 115^\circ) \\ & & \theta &= 39.8^\circ \end{aligned}$$

Thus, the direction ϕ (phi) of \mathbf{F}_R , measured from the horizontal, is

$$\phi = 39.8^\circ + 15.0^\circ = 54.8^\circ \quad \textit{Ans.}$$

Contoh 2

Resolve the horizontal 600-lb force in Fig. 2–12a into components acting along the u and v axes and determine the magnitudes of these components.

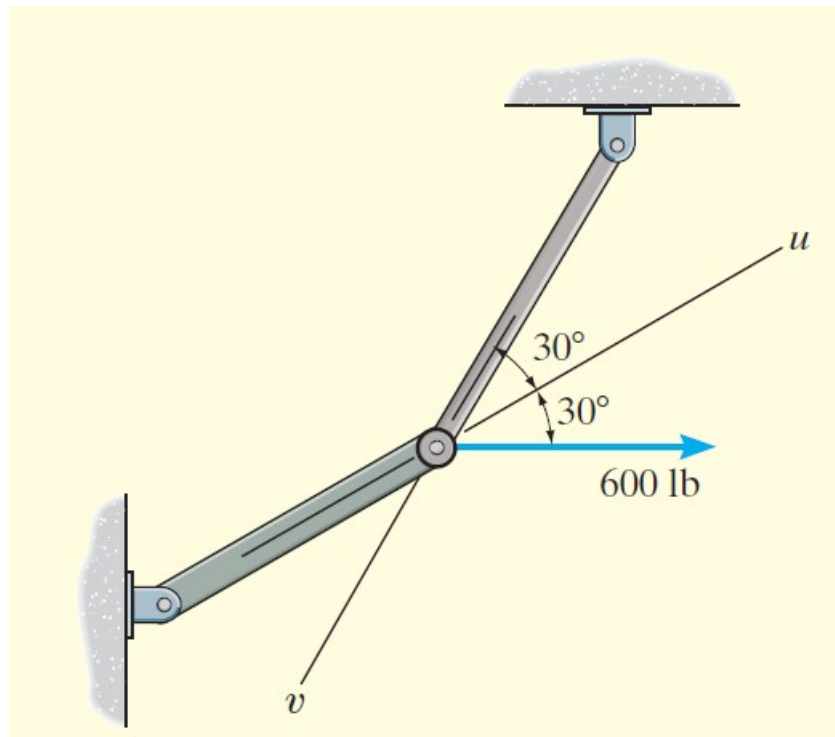

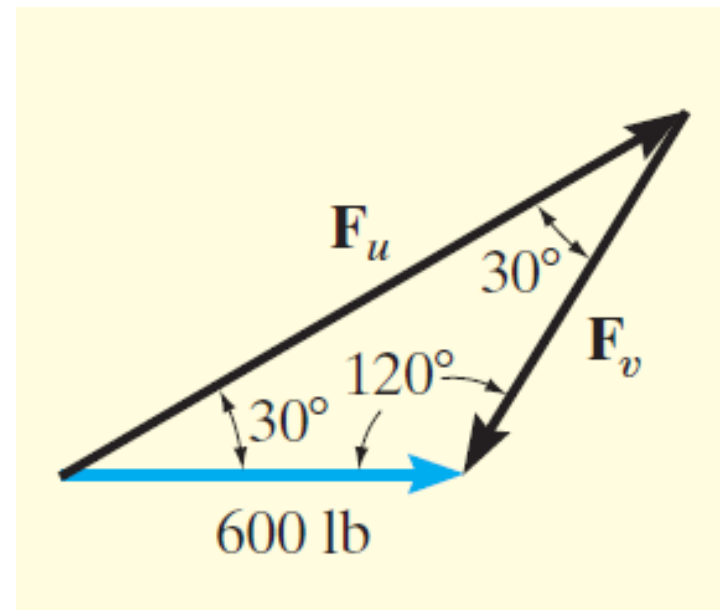
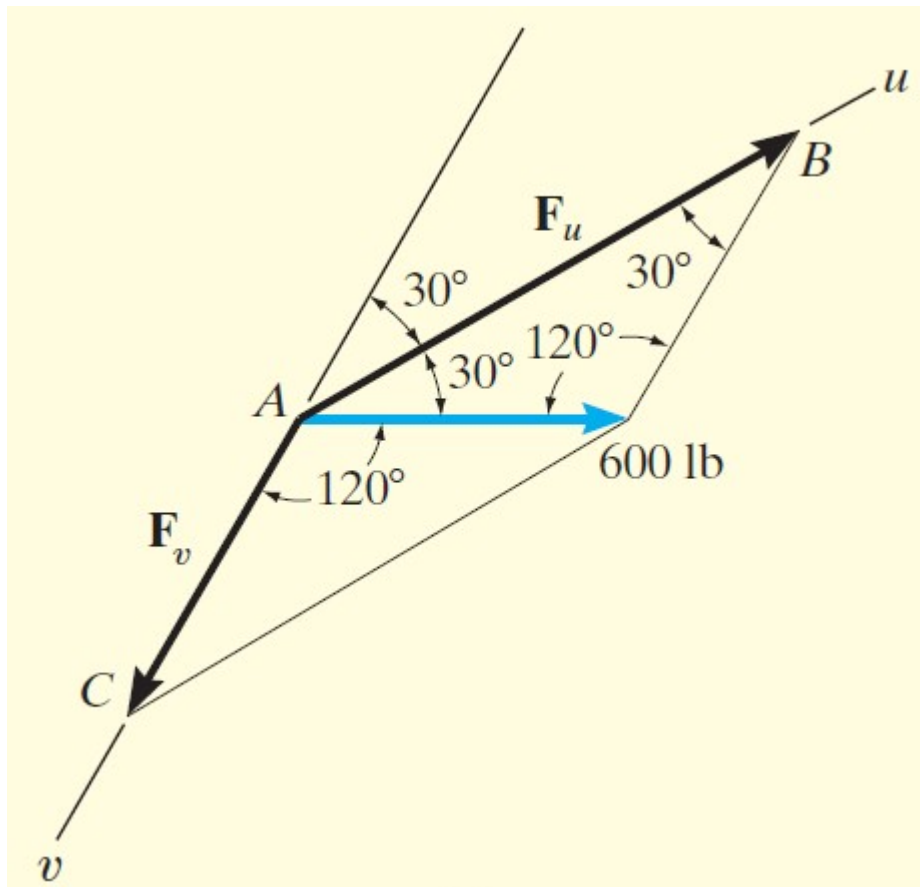

$$\frac{F_u}{\sin 120^\circ} = \frac{600\text{ lb}}{\sin 30^\circ}$$

$$F_u = 1039\text{ lb}$$

$$\frac{F_v}{\sin 30^\circ} = \frac{600\text{ lb}}{\sin 30^\circ}$$

$$F_v = 600\text{ lb}$$

Contoh 3

Determine the magnitude of the component force \mathbf{F} in Fig. 2–13a and the magnitude of the resultant force \mathbf{F}_R if \mathbf{F}_R is directed along the positive y axis.

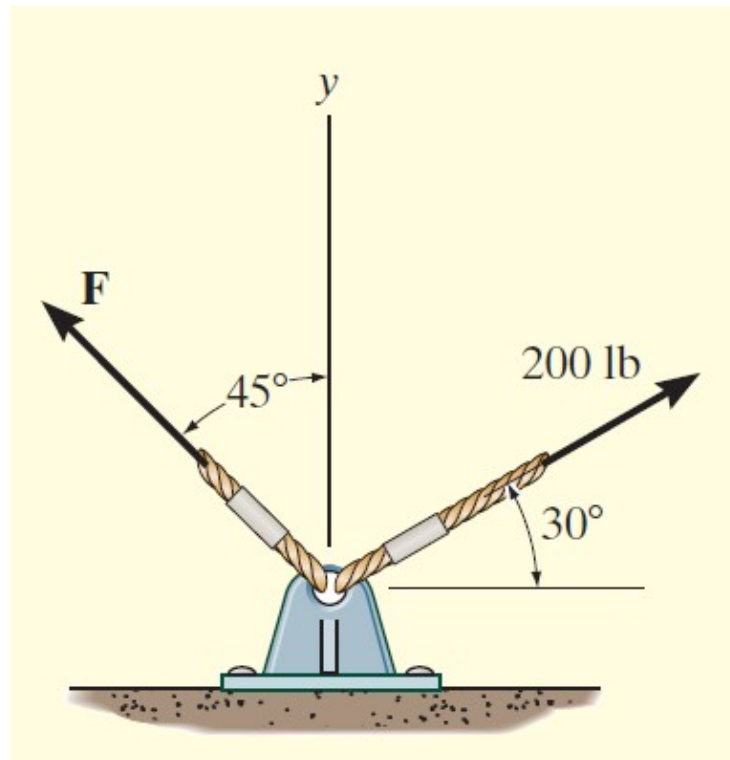

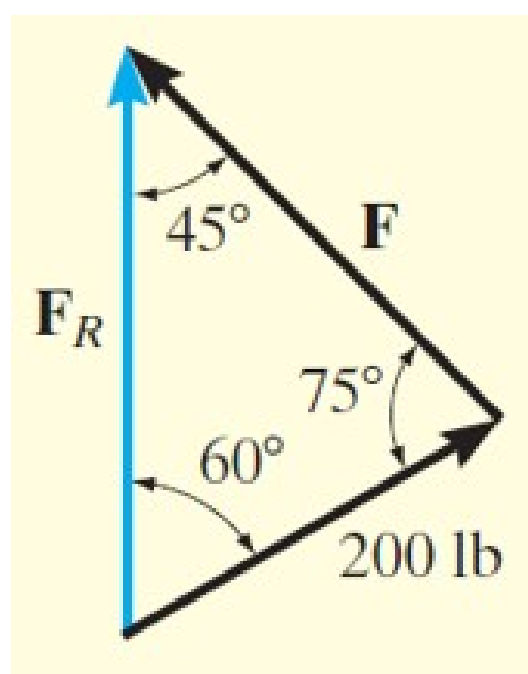
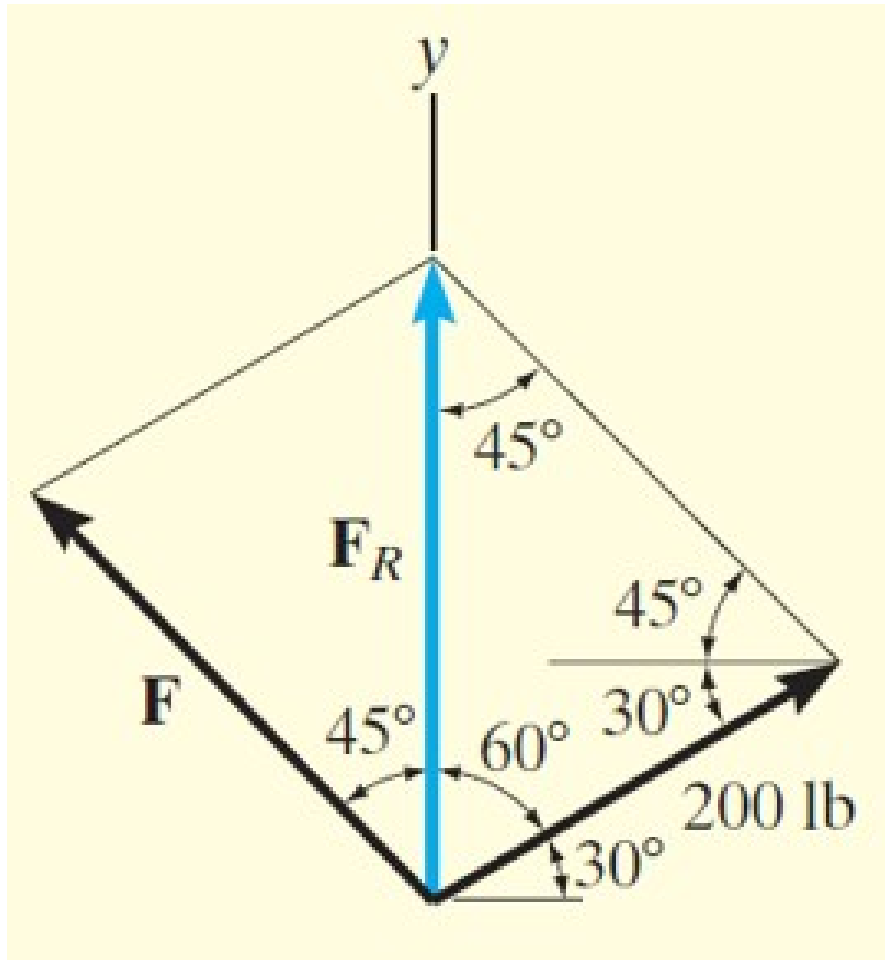

$$\frac{F}{\sin 60^\circ} = \frac{200 \text{ lb}}{\sin 45^\circ}$$

$$F = 245 \text{ lb}$$

$$\frac{F_R}{\sin 75^\circ} = \frac{200 \text{ lb}}{\sin 45^\circ}$$

$$F_R = 273 \text{ lb}$$